

THE JR BOWL

This is a bowl turning method designed to help those who have difficulty getting a nice curve on the outside of a bowl.

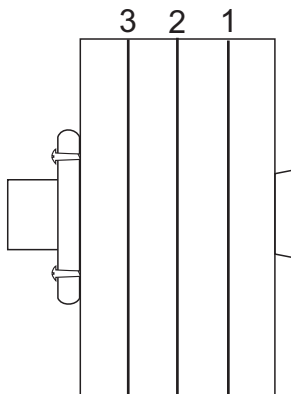

Mount the blank on a faceplate or screw chuck. Round it off and cut a spigot (chuck bight). On the rounded sides mark three lines to divide the side into quarters. From as close as possible to the spigot cut straight to the outermost line (line No 1) on the rounded side.

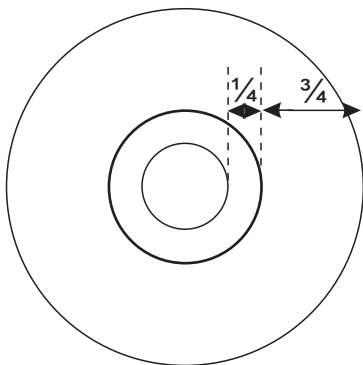
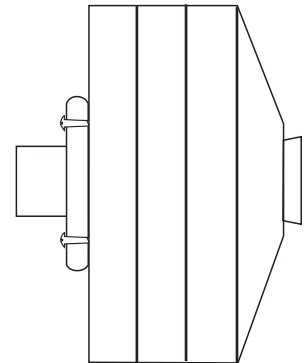

On the flat you have just cut mark a circle at one quarter of the distance from the spigot to the edge of the round. Cut straight from that circle to the centre mark (line No 2) on the rounded side.

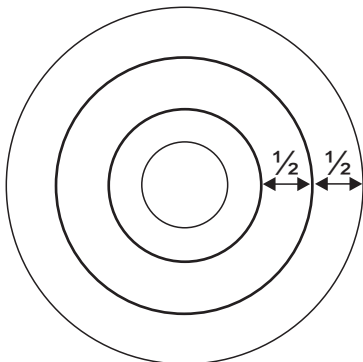
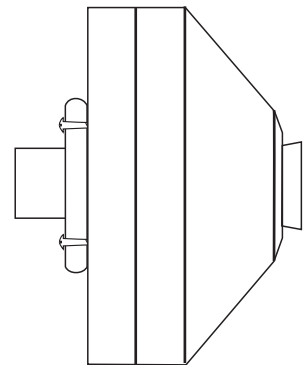

On the flat you have just cut mark a line at half the distance from the first circle to the edge of the round. Cut straight from that line to the left hand mark (line No 3) on the rounded side.

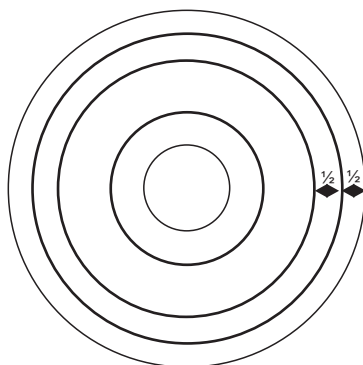
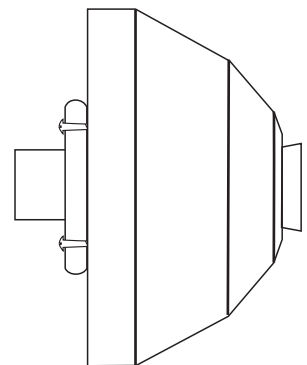

On the flat you have just cut mark a line at half the distance from the second circle to the edge of the round. Cut straight from that line to the face of the blank.

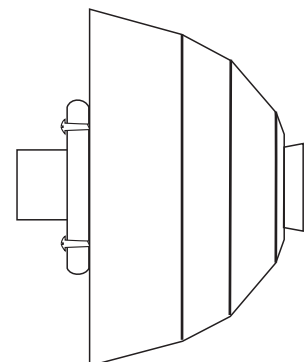

Now, gently cut away the high points to get a nice curve to the bowl.