



A CHATTER TOOL

The Chatter Tool can be made from water pipe, thick-walled steel tube, various lumps of steel, and a variety of other media. This pattern utilises steel. It is desirable to have a very rigid, and preferably heavy, handle on the chatter tool. These drawings are not to scale



Take a 200mm length of 20mm dia steel and drill a 13mm hole at least 40mm into one end.



Drill and tap a hole to take a small bolt to hold the chatter blade in place. A 4mm bolt started 6mm back from the end is recommended. Cut the bolt to minimise any protrusion when it is tight.

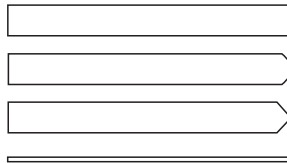

Make or buy a chatter blade that is about 70mm x 10mm. The thickness and spring in this steel will determine the quality of chatterwork you can achieve. About 1.5mm spring steel is recommended. You can leave the end square, or rounded, or to a point. When viewed from the side the sharpen is always perfectly square.

Assemble the tool and put it to use. You may add a small round wooden handle for comfort.

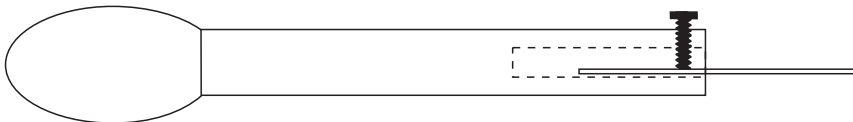

Chatter work can be done only on the end grain of wood and some acrylics. Hard woods give better results than soft woods.

The quality and spacing of the chatter depends on a variety of things: length of the chatter blade; quality of steel in the blade; hardness of the wood; angle of presentation to the wood; speed of the lathe.

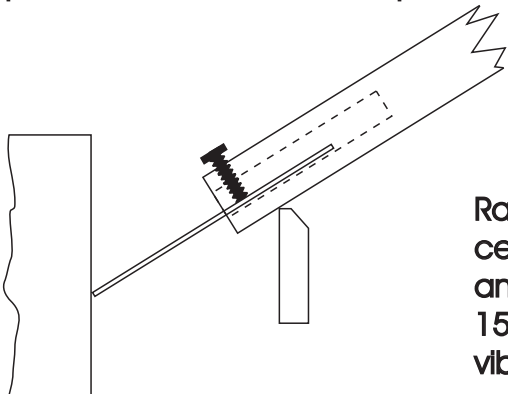

Raise the toolrest so that the chatter blade is at the centre line of the work and on about a 45 degree angle. Lathe speed usually needs to be more than 1500rpm. Apply sufficient pressure to get the blade vibrating.