

Bandsaw Circle-cutter

The jig, made from plywood, has a base, a pivot board, and a stop block attached to the base.

To use, clamp the base to the bandsaw table so that the pivot pin and the circle holes are lined up with the front edge of the bandsaw blade. Lift the pivot board off the base and install a pin in the desired circle hole. Centre the blank on the pin. Fit the pivot board back on the base with the blank well clear of the saw blade. Start the bandsaw and swing the pivot board in to the saw blade which will cut a reverse circle into the scrap area of the blank. When the pivot board meets the stop block, rotate the blank to cut a circle.

An advantage of this jig is the ease of changing circle diameters. Just lift off the pivot board and reposition the circle centre pin. There is no need to remove the whole unit from the bandsaw.

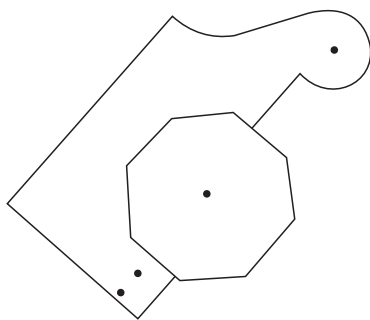
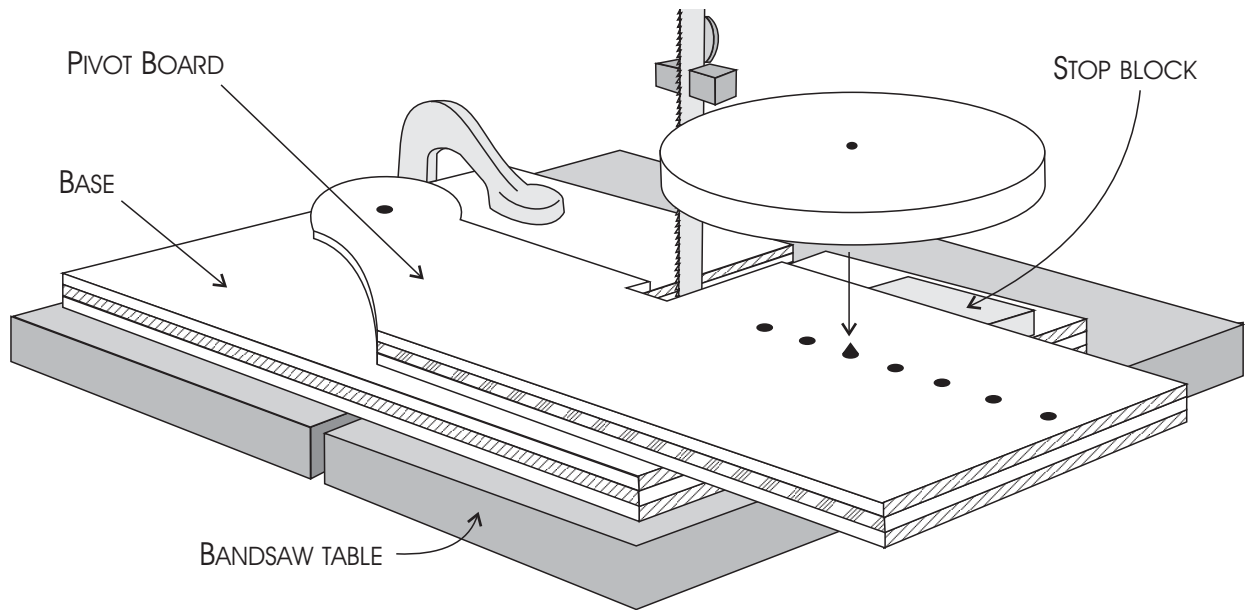

PLACE BLANK ON
PIVOT BOARD

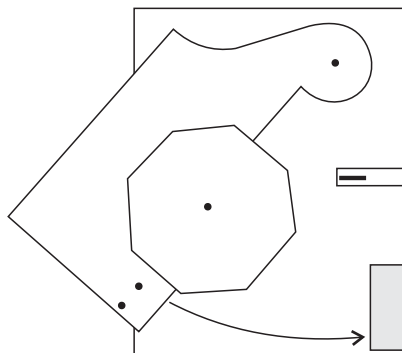

SWING PIVOT
BOARD IN TO SAW

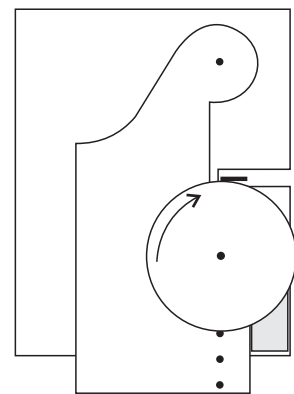

TURN THE BLANK