

Parting Tool Support

There are occasions in woodturning when it is desirable to have your parting tool, or some other tool, pushed forward in a straight and controlled manner. The support shown here is intended for that style of work. This support may be made of steel or wood and may be adjustable for different thicknesses and heights of chisel.

If you think you will use only one thickness of chisel then all parts can be firmly welded or glued together. For options for future use with other chisels, one side of the upper part may be securely attached. Then the other side can be moved and locked in place to accommodate chisels of varying thickness.

No dimensions or construction methods are shown as there are too many options to be considered.

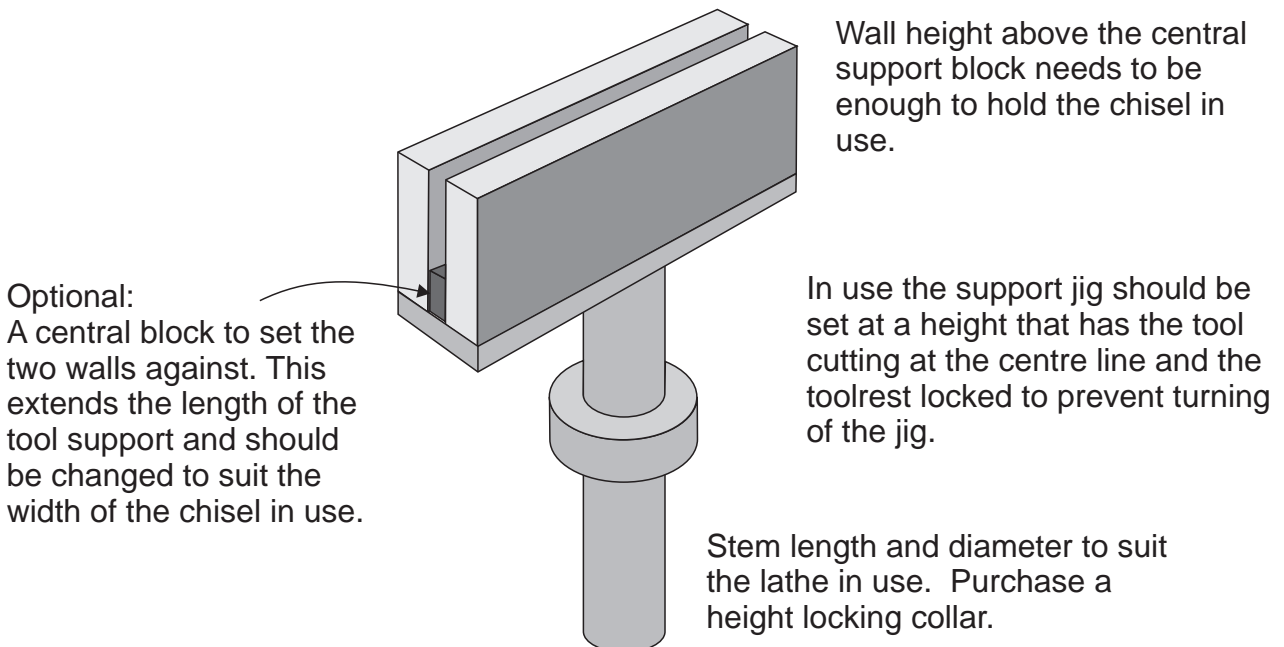

If necessary, ensure that the parting tool is shaped to fit a curving cut.

