

Cone Streptohedron

From David Springett in his books Woodturning Wizardry and Woodturning Full Circle.

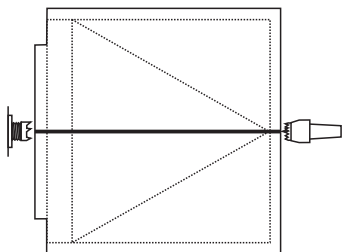

Start with a block that is two halves of a 65 mm cube cut and rejoined with a paper or double-sided tape joint at the centre. Mount this accurately between centres with the paper joint perfectly on centre and in line with the lathe drive. Round it off and make a spigot for a 50 mm chuck on one end.

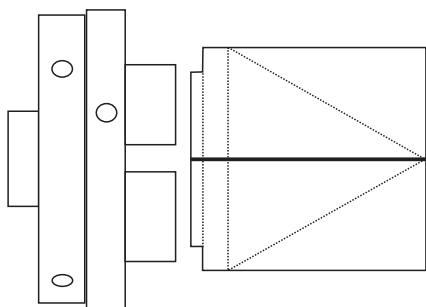

Mount the work in a chuck. Turn it to exactly 60 mm diameter. Dress the tailstock end of the wood to be flat and put a pencil mark at the centre. Mark a line around the wood 52 mm from the tailstock end.

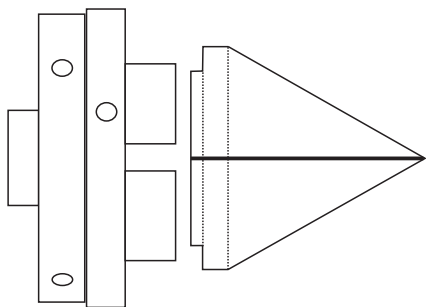

Turn the wood to a cone shape between the 52 mm mark and the pencil dot on the end. Sand and finish this surface.

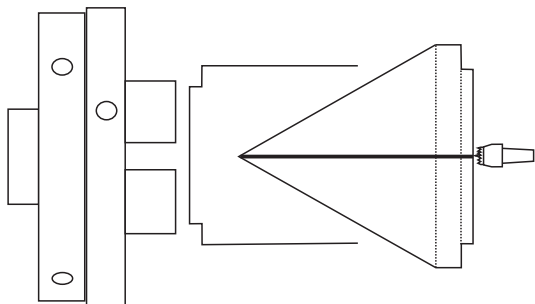

You now need to turn the wood around to finish the other end. Make a jam chuck and use Tape or hot melt glue to hold the wood while it is turned. Bring up the tailstock for added security. Turn the tailstock side to be perfectly flat. Sand this side

Remove the wood from the lathe. Split the joint and ensure the two faces of the wood are clean and smooth. Rotate one of the two parts through 120 degrees and glue the wood together. Sand and finish.

