



Removable Indexing Plate

This indexing pin is used with a thin steel index plate fitted between the chuck and lathe head. Two alternatives are shown here for the vertical part of the indexing pin. This setup can be added to, or removed from, the lathe at any stage in the turning process while the turned work remains in the chuck.

This drawing is not to scale and the whole rig must be made to fit the size of your lathe and your index wheel.

Spring loaded indexing pin. At centre height for convenience, but must not be lower than the innermost index ring.

Indexing pin on flexible upright. At centre height for convenience, but must not be lower than the innermost index ring.

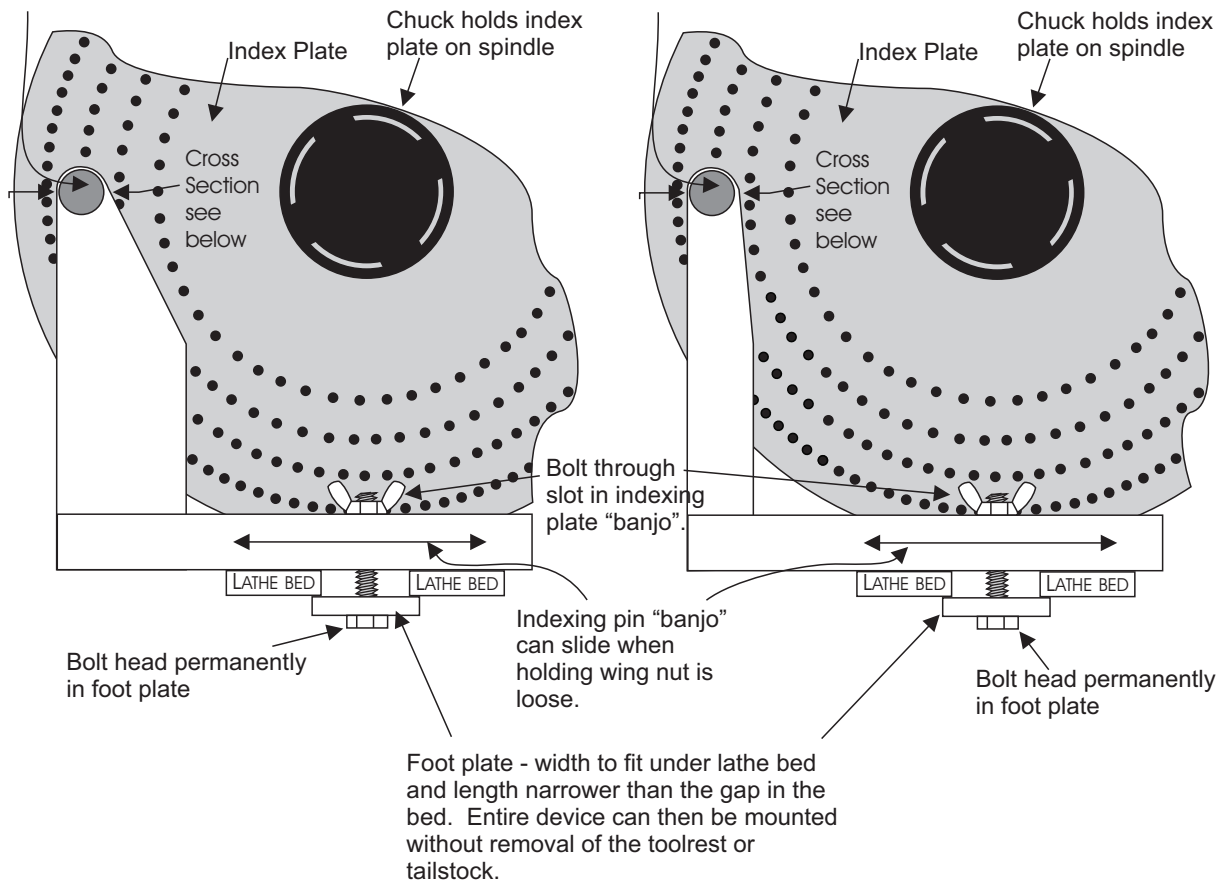

Double thickness of rigid material to allow creation of the internal space.

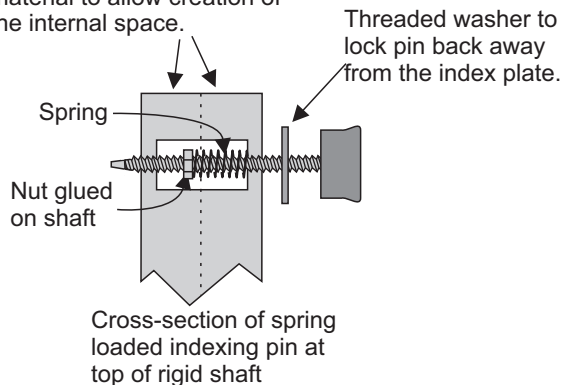

Single thickness of flexible material with fixed knob and pin.

