

A SQUARE BOWL

Note: The drawings shown here are not to scale. Your chucks, your faceplates, and your wood, may all be slightly, or considerably, different in size.

For your first square bowl I suggest a block of medium density wood 200 x 50mm. You may progress to smaller or larger work, or long rectangles, or rectangular with the bowl offset.

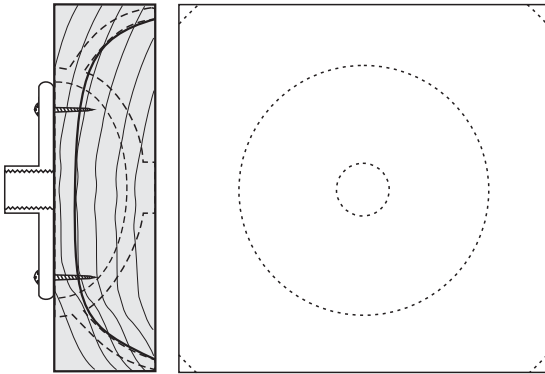

Cut the wood perfectly square and dress the four narrow sides. Plan the shape of the bowl, and the wings, carefully bearing in mind the steps needed to clean the foot off the bowl later. On at least one side of the wood draw the curve that will flow from foot to foot right across the underside of the bowl rim. Mount this wood perfectly central on a faceplate or screw chuck. When using a faceplate be sure that the screws are inside or outside your intended finished work. Rotate the wood slowly to mark the outer face with a pencil held firmly on the toolrest. Check that the wood is perfectly central on the faceplate or screw chuck.

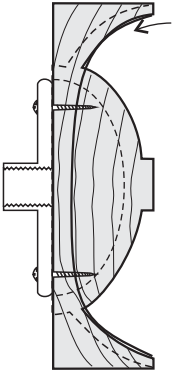

For most of this bowl use a freshly sharpened 10mm bowl gouge with a cutting angle of about 35°. Start the cuts near the corners with care to avoid breaking off the entire corner. Initially you will be cutting a lot of air so use as much speed as you are comfortable with. The curve you have drawn, and the cuts you now make, will later determine the more visible curve on the upper side of the bowl. Cut the complete underside of the bowl. Create a spigot for reversing the bowl onto a chuck later to cut the upper side. Sand to a finished condition all of the underside except the spigot.

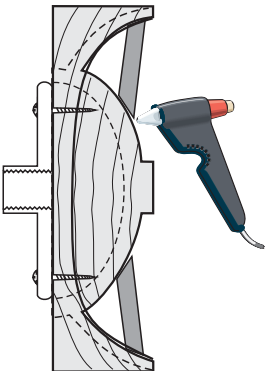

If you are planning thin legs at the corners of the work, or the wood is fragile, the corners will need some support. Apply a sealer to all of the underside of the work to reduce hot melt glue flow into the pores of the wood. Then use hot melt glue to add a wooden strut between each corner and the body of the work.

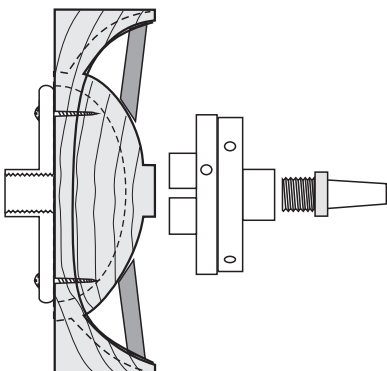

To get perfect consistency in the thickness of the square bowl edges and the size of the four feet it is very important to remount the bowl on a chuck perfectly. This can be helped by using a reverse adapter to hold a chuck on the tailstock. Slide the tailstock and chuck up to the bowl and grip the spigot. Now remove the entire assembly of faceplate, bowl, and chuck from the lathe. Remove the faceplate and return the work to the lathe mounted on the chuck.

A SQUARE BOWL page 2

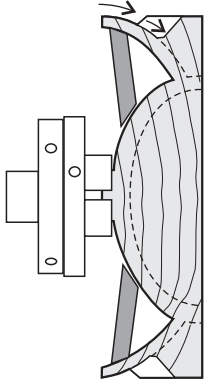

With the wood turned over and held in a chuck, start turning the top side from the extremities of the wings by thinning down to the desired thickness bit by bit while leaving adequate support further in towards the bowl proper.

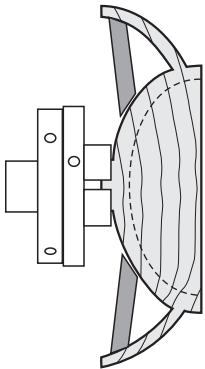

Complete the wings. Get an even thickness of the wood edges that show between the feet. Ensure that outer edge of the bowl rim is an exact continuation of the curve from the bowl bottom. Hollow the bowl. Here it will be easier to use a 10mm bowl gouge with a cutting angle of about 55°. Sand the top side and edges to a finished condition. You can now apply the finish of your choice to the top side.

Remove the work from the chuck. Remove the struts supporting the wings. You can use a hot air gun, denatured alcohol, acetone, or lacquer thinners to soften the glue. The struts may lift off or be assisted by the use of a hot knife. Then clean the work with denatured alcohol, acetone, or lacquer thinners.

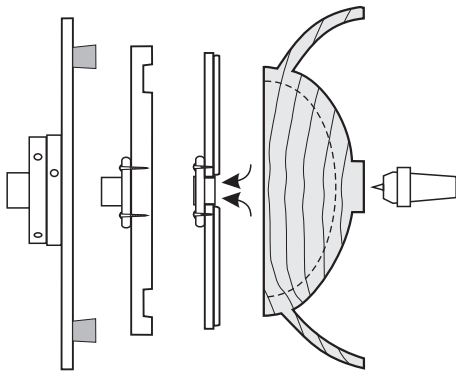

A square bowl of this shape may be held in Cole jaws (an external fit, possibly with shortened buttons), or a jam chuck, or a vacuum chuck, or pressed against a faceplate with the tailstock. It could have been designed with a taller bowl rim to ensure an easy fit in Cole jaws.

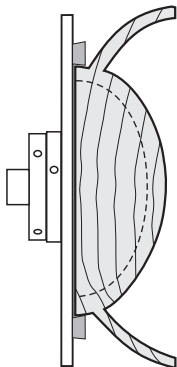

Cut away the spigot. Sand all the underside of the bowl to a finished condition. You can now apply the finish of your choice to the under side and edges.

