

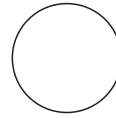

## Steady for DVR 2024

Four wheels are used.  
Each one bolted between a pair of the wheel steel parts shown.  
Two coach bolts through the slots in the wheel steel allow the wheels to be used in any position or fewer than the four wheels may be used.



Roller Blade wheel 72mm dia  
25 thick 8mm axle

Wheel centre to outer edge 350mm

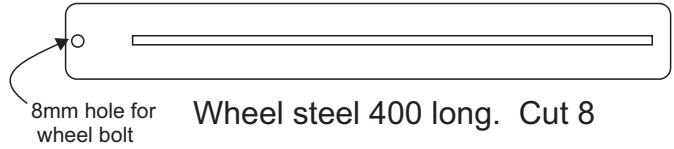

Wheel steel 400 long. Cut 8

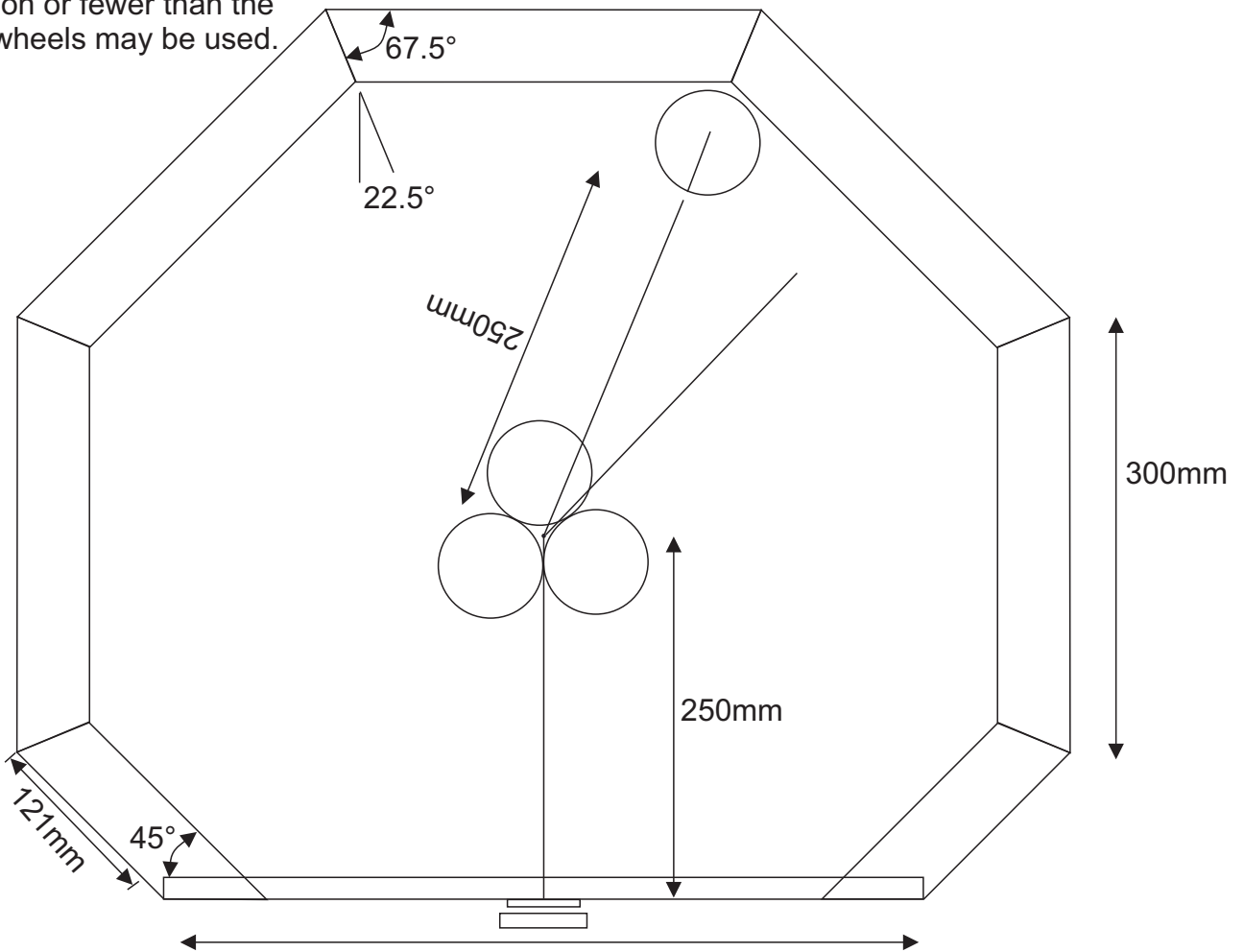

520 x 10 x 100 base plate

50 x 5 x 80 Centering plate  
welded or screwed to base plate

60 x 10 x 45 locking plate.  
Tap the centre of this and drill  
a hole for a bolt to come down  
from above the base plate.

20mm on plan = 100mm on steady

