

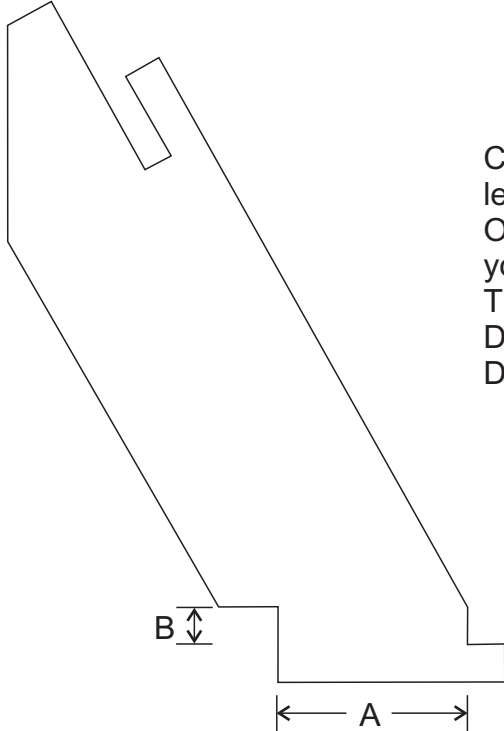

HOLD A SPINDLE TURNING STORY BOARD

The story board is made from thin hardboard or plywood. It should be only a little bit longer and wider than the spindle turning plan that is pasted or taped onto it.



Cut two story board supports, as shown to the left, from thick ply.

Overall height is about the spindle height of your lathe.

The lean back is about 30°.

Dimension A is the width of gap in lathe bed.

Dimension B is the thickness of lathe bed.

For Lengths

You can mark the story board and bring it up to transfer marks to the spindle.

Or write measurements, from either end of the wood, on the story board and then measure the spindle.

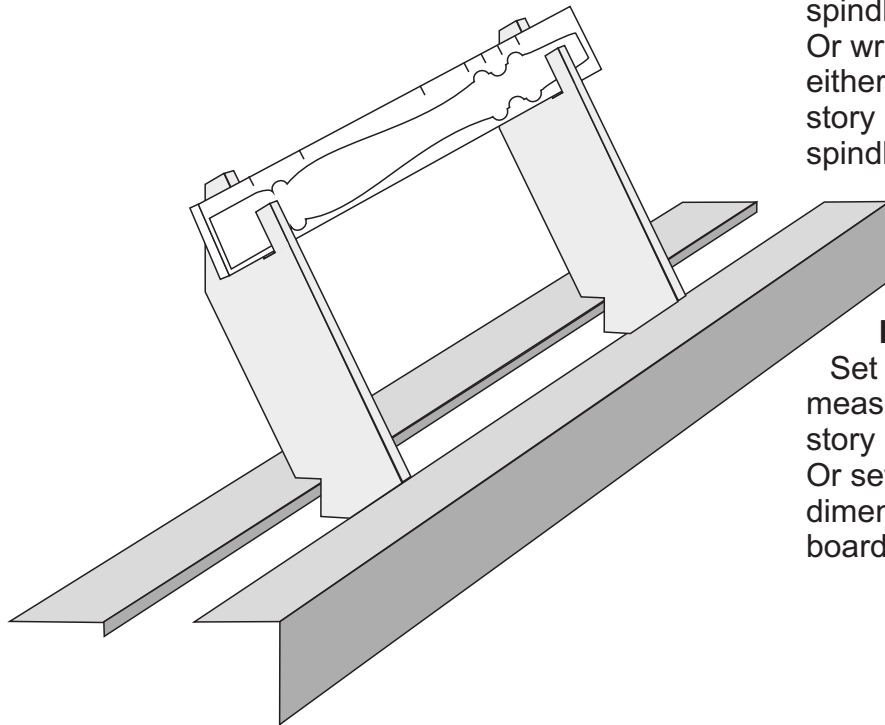

For Diameters

Set callipers to the measurements shown on the story board.

Or set the callipers to the dimensions shown on the story board.